



NOTICE DE MONTAGE ET DE RACCORDEMENT

DISPOSITIF DE VERROUILLAGE ELECTROMAGNETIQUE ENCASTRE



1. GENERALITES

Montage: en encastré
Force: 300 Kgs (600 Lbs)
Alimentation: 12 Vdc/0.5A-24Vdc/0.25A
Caractéristiques: Signal de sortie
Conformité CE directives en vigueur

2. IDENTIFICATION



A. 1 ventouse



B. 1 contreplaque



C. 1 gabarit

D. 1 notice de montage

E. 1 sachet de montage

Détails du contenu du sachet de montage



E1. 1 bouton Ø12mm x 34mm



E2. 1 tête TFHC Ø8mm x 35mm



E3. 1 rondelle silicone blanche



E4. 8 vis tête fraisée Ø4mm x 25mm



E5. 2 goupilles de centrage Ø4mm



E6. 1 Clé 6 pans de 5mm



E7. 1 Clé 6 pans de 3mm

E8. 1 rondelle métallique
(en supplément, si besoin serrage)

3. PRECAUTIONS D'INSTALLATION

IMPORTANT : A LIRE AVANT L'INSTALLATION DE LA VENTOUSE

- Manipuler le produit avec attention ; abîmer la surface de l'aimant ou la contre plaque peut réduire l'efficacité du système de fermeture
- La contre plaque doit avoir du jeu pour adhérer au mieux à la ventouse. La ventouse, au contraire, est fixée sur l'encadrement de la porte et ne doit pas bouger.
- Fixer la ventouse lorsque la porte est fermée

4. MONTAGE

4.1 VU D'ENSEMBLE

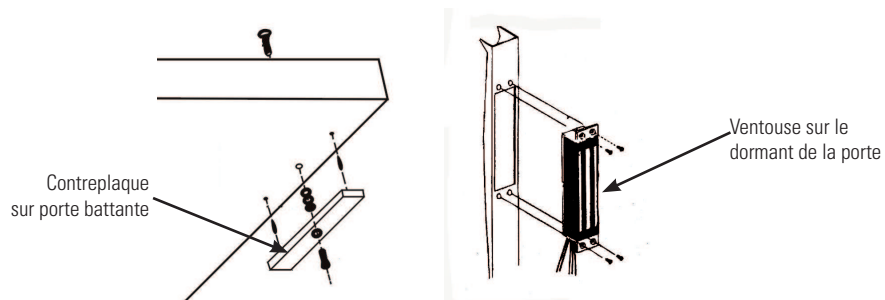

4.2 MONTAGE DE LA CONTRE PLAQUE

Pose du Gabarit

1. Placer le gabarit C sur la porte

2. Percer deux trous Ø4.5mm et un trou Ø8mm

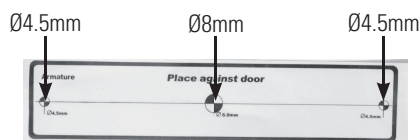

Pose de la Contreplaque

ATTENTION: Veiller à conserver un léger mouvement au niveau de la contreplaque, de manière à pouvoir compenser un mauvais alignement.

1. Insérer les 2 goupilles E5

2. Insérer la tête TFHC E2

3. Insérer la rondelle en plastique E3

4. Fixer la contre plaque sur la porte

5. Assembler avec le bouton E1

6. Serrer avec la clé E7

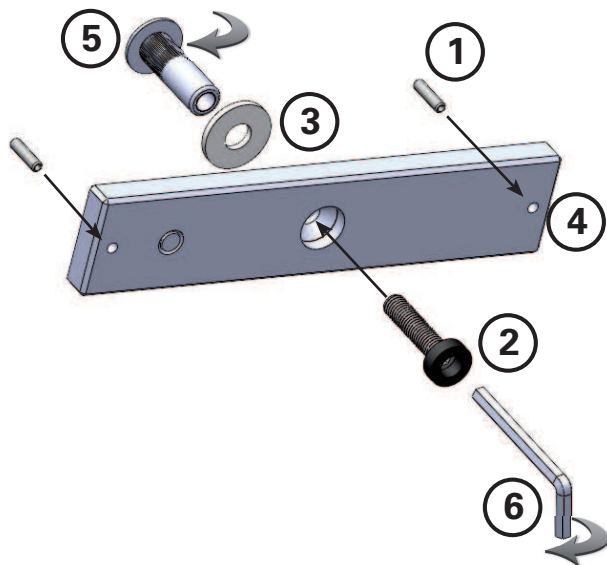

4.3 MONTAGE DE LA VENTOUSE

1. Insert the EM lock

2. Fix with screws and proceed with cabling

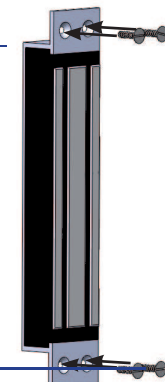

4. WIRING

- 12VDC - 0.5A - Position the switch on 12Vdc - connect the black wire to the power supply (-) and connect the red wire to the power supply (+)
- 24Vdc - 0.25A. Position the switch on 24Vdc - connect the black wire to the power supply (-) and connect the red wire to the power supply (+)

Printed circuit board schematic:

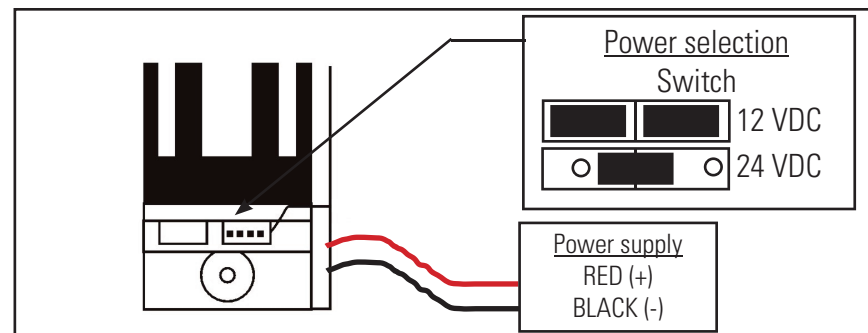

4. TROUBLE SHOOTING

PROBLEM	REASON	SOLUTION
Door does not lock	No power supply	Check to make sure the wires are securely tightened to the correct terminal block.
		Check that the power supply is connected and operating properly
		Make sure about the polarity (cabling wise)
Reduced holding force	Poor contact between EM lock and armature plate	Make sure the electromagnet and armature plate are properly aligned
		Make sure the contact surfaces of the electromagnet and armature plate are clean and free from dust
	Low voltage or incorrect voltage setting	Ensure the electromagnet lock is set for the correct voltage and the voltage selection jumpers are placed correctly
		Check for proper voltage at the electromagnetic lock input that could be the cause of voltage drop

4. MOUNTING

4.1 GENERAL

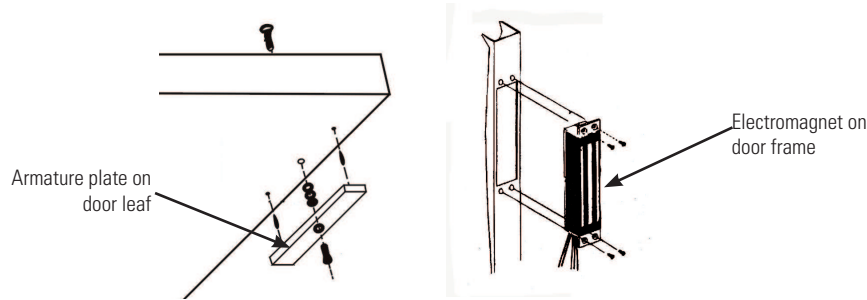

4.2 ARMATURE PLATE MOUNTING

Template

1. Place the template against the door

2. Drill two Ø4.5mm holes and one Ø8mm hole



Armature plate mounting

CAUTION: The armature plate faces must be able to pivot slightly about its center mounting screw to compensate for any door misalignment.

1. Insert the 2 guide pins E5

2. Insert the armature bolt E2

3. Insert the white washer E3

4. Place the armature plate against the door

5. Fix armature plate with nut E1

6. Screw with Allen wrench E7

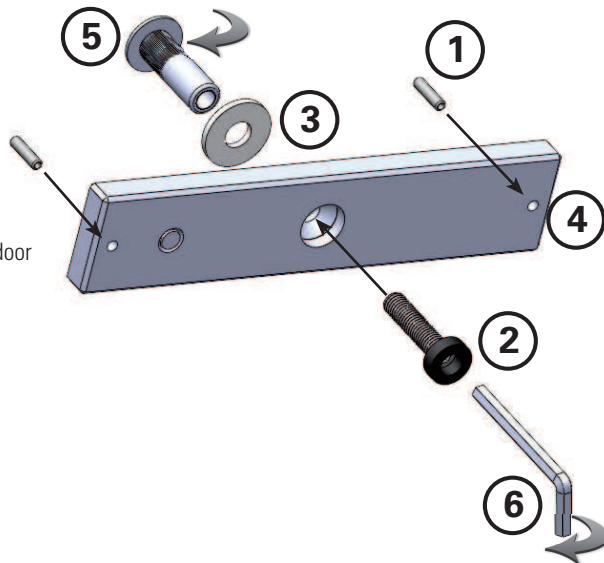

4.3 MONTAGE DE LA VENTOUSE

1. Encastrer la ventouse

2. Fixer avec les vis fournies, puis câbler selon schéma ci-dessous

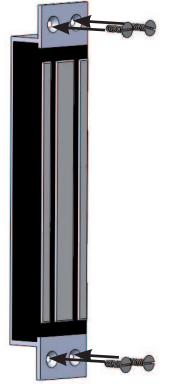

4. BRANCHEMENTS

- 12Vdc - 0.5A: les pontets se placent sur la position 12Vdc.
Connecter le fil noir à l'alimentation (-) et
Connecter le fil rouge à l'alimentation (+)
- 24Vdc: les pontets se placent sur la position 24Vdc
Connecter le fil noir à l'alimentation (-) et
Connecter le fil rouge à l'alimentation (+)

Schéma du circuit imprimé:

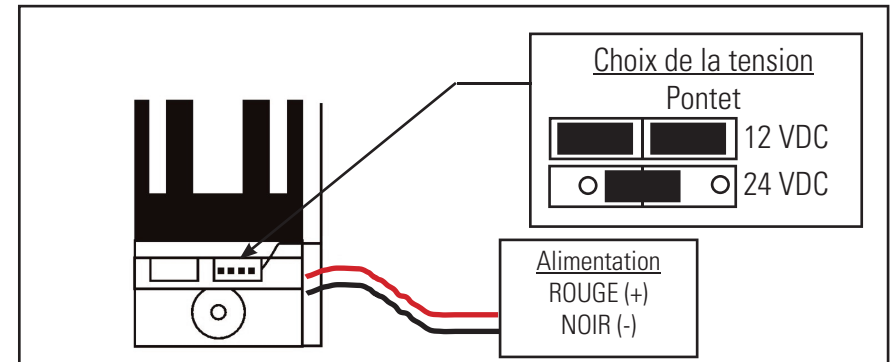

4. AIDE AU DEPANNAGE

PROBLEME	CAUSE POSSIBLE	SOLUTION
La porte ne ferme pas	Pas d'alimentation	Vérifier que les fils soient bien vissés sur le bornier
		Vérifier la présence d'alimentation
		Vérifier la polarité (sens de branchement)
La force de maintien est faible	Faible pouvoir de contact entre la ventouse et sa contreplaque	Vérifier l'alignement de la ventouse et de la contreplaque
		Vérifier que la surface de contact entre la ventouse et la contreplaque soit propre et sans poussière
	Baisse de tension ou tension incorrecte	Vérifier la tension d'alimentation et la position des pontets
		Vérifier la section des câbles d'alimentation qui pourrait être la cause de la chute de tension



USER GUIDE AND WIRING GUIDELINES

MORTICE MOUNT ELECTROMAGNETIC LOCK



1. GENERAL FEATURES

Mounting:	Mortice mount
Holding force:	300 Kgs (600 Lbs)
Current draw:	12 Vdc/0.5A-24Vdc/0.25A
Features:	Output signal
Comply with CE directives	

2. IDENTIFICATION



A. 1 EM lock



B. 1 armature plate



C. 1 template

D. 1 user guide

E. 1 plastic bag with mounting acc.

Detail of bag content



E1. 1 nut Ø12mm x 34mm



E2. 1 armature bolt Ø8mm x 35mm



E3. 1 white rubber washer



E4. 8 fixing screws Ø4mm x 25mm



E5. 2 guide pins Ø4mm



E6. 1 allen wrench 5mm



E7. 1 allen wrench 3mm



E8. 1 steel washer
(if necessary)

3. INSTALLATION RECOMMENDATIONS

IMPORTANT : PLEASE READ BEFORE ATTEMPTING TO INSTALL MAGNETIC LOCK

- Handle the product with care, damaging the mating surfaces of the magnet or armature plate may reduce locking efficiency.
- The magnet mounts rigidly to the door frame. The armature plate faces must be able to pivot slightly about its center mounting screw to compensate for any door misalignment
- Install EM lock when door is in its normally closed position