

A (1:1)

MONTAGE DE 4 ECROUS M4X0.7 A SERTIR

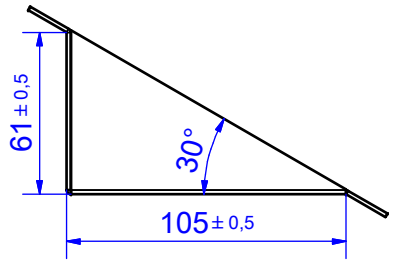
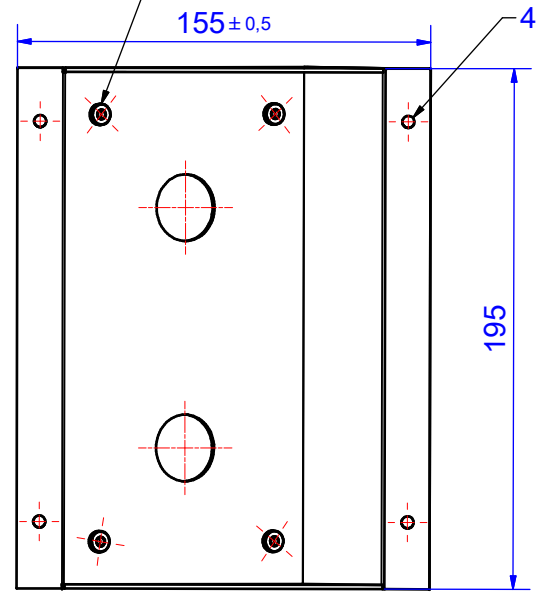

Aucunes marques, aucunes tâches, aucunes rayures sont acceptées sur les faces extérieures

Ebavurer les arrêtes vives

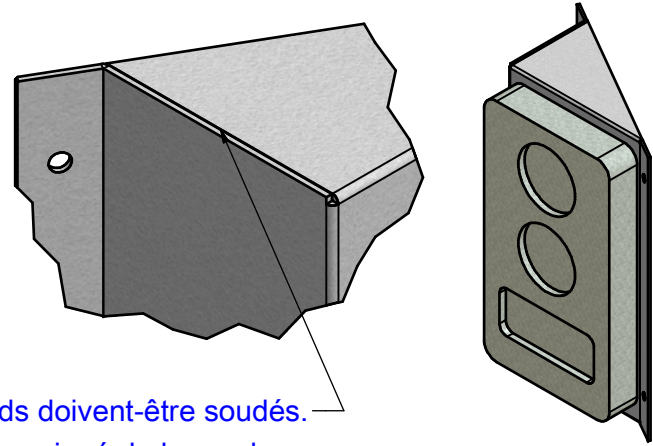

Les 2 bords doivent être soudés.  
Meulage soigné de la soudure.

Tolérances générales selon ISO 2768 m

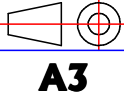
A	18/09/12	s moreau	Création	
Ind	Date	Auteur	Description	
Dessiné par: s moreau		Vérificateur:		Date: 18/09/2012 Ech: 1
 A3		<b>60-001-AP1 SUPPORT MIKRA</b>		
FDI MaTelec Route de St-Symphorien B.P.69 85130 Les Landes Génusson Tél. 02 51 61 69 69 Fax: 02 51 61 69 68 e-mail. info@fdimatelec.com				Indice: <b>A</b>
Matière: Inox 316L Ep:1.5mm finition Microbillée				Feuille: 1 / 1